

25. INSTALLATION NOTES

Mounting:

The power terminal shall be located on top of the unit. An appropriate electrical and fire end-product enclosure should be considered in the end use application.

Cooling: Convection cooled, no forced air cooling required. Do not obstruct air flow!

Installation clearances: 40mm on top, 20mm on the bottom, 5mm on the left and right side are recommended when loaded permanently with full power. In case the adjacent device is a heat source, 15mm clearance are recommended.

Risk of electrical shock, fire, personal injury or death!

Turn power off and disconnect battery fuse before working on the DC-UPS. Protect against inadvertent re-powering.

Make sure the wiring is correct by following all local and national codes. Do not open, modify or repair the unit.

Use caution to prevent any foreign objects from entering into the housing.

Do not use in wet locations or in areas where moisture or condensation can be expected.

Service parts:

The unit does not contain any service parts. The tripping of an internal fuse is caused by an internal fault. If damage or malfunctioning should occur during operation, immediately turn power off and send unit to the factory for inspection!

Wiring and installation instructions:

- (1) Connect the power supply to the input terminals of the DC-UPS.
- (2) Connect the battery to the battery terminals of the DC-UPS. It is recommended to install the battery outside the cabinet or in a place where the battery will not be heated up by adjacent equipment. Do not install the battery in airtight housings or cabinets. The battery should be installed according to EN50272-2, which includes sufficient ventilation. Batteries store energy and need to be protected against energy hazards. Use a 30A battery fuse typ ATO® 257 030 (Littelfuse) or similar in the battery path. The battery fuse protects the wires between the battery and the DC-UPS. It also allows the disconnection of the battery from the DC-UPS which is recommended when working on the battery or DC-UPS. Disconnect battery fuse before connecting the battery.
Please note: Too small or too long wires between the DC-UPS and the battery can shorten the buffer time or can result in a malfunction of the DC-UPS. Do not use wires smaller than 2.5mm² (or 12AWG) and not longer than 2x1.5m (cord length 1.5m). Avoid voltage drops on this connection.
- (3) Connect the buffered load to the output terminals of the DC-UPS. The 24V output is placed on top of the unit. The 12V output is placed on bottom of the unit behind the signal plug. The output is decoupled from the input allowing load circuits to be easily split into buffered and non buffered sections. Noncritical 24V loads can be connected directly to the power supply and will not be buffered. The energy of the battery can then be used in the circuits which require buffering.
- (4) Install the battery fuse when the wiring is finished.

Fig. 25-1 Typical wiring diagram

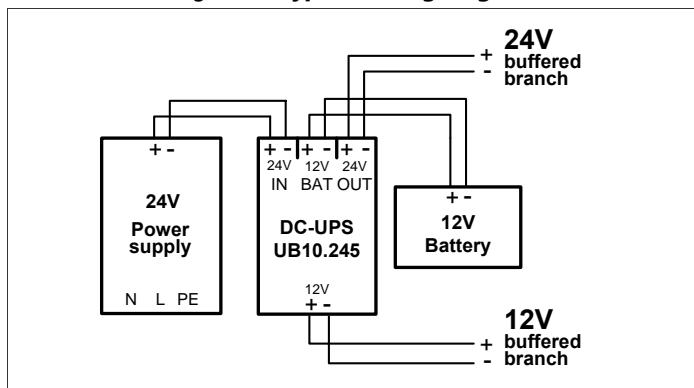

May, 2008 / Rev. 1.0 Datasheet DS-UB10.245-EN

All parameters are specified at an input voltage of 24V, 10A output load, 25°C ambient and after a 5 minutes run-in time unless otherwise noted. It is assumed that the input power source can deliver a sufficient output current.